

LINELIGHT R1

Specifications



Why us?

Innovative Technology

High-efficiency solar and advanced LEDs deliver superior performance, long life, and maximum ROI.

Photometric

We conduct photometric measurements on all our products to ensure optimal performance and compliance with industry standards

Versatile Lighting

We design and install solar-powered lighting systems tailored for all kinds of locations such as streets, parks, pathways, homes, etc.

Global Reach

Worldwide success proves our adaptability and regulatory expertise.

Sustainable Savings

These solutions enhance safety, promote sustainability and provide significant energy and cost savings.

Warranty

SolarPath is dedicated to delivering architectural and commercial-grade solar lighting that can be customized to meet specific client requests, both in technical specifications and aesthetic design, ensuring a perfect fit for a diverse range of needs.



The LineLight R1 is a high-intensity, heavy duty wired marker for uni-directional marking. A fixed base and a removable main unit body allows for easy maintenance if needed.



Technical Specifications

Technology and Operation

Energy source	Solar modules External DC feed Hybrid - Solar & External DC backup feed
Energy consumption	12V-24V DC, 80mA
Illumination technology	12 x Ultra-bright Φ 3mm/0.11" LEDs.
Operating temperature range	-22F to +185F / -30C to +85C
Warranty	2 Years

Illumination Properties

Available flash patterns	Controllable - Flashing, Steady or Sequential				
Available colors	White, Blue, Red, Green, Amber				
Lighting intensity (mcd)	Amber	Red	White	Blue	Green
	4500	3500	6400	3200	11000
Light visibility distance	Up to 3,280 feet / 1km (varies according to weather conditions)				

Material and Design

LED protector	UV-treated Polycarbonate
Case	Aluminum & Anti-corrosion stainless steel
Compressive strength	1,000kg/cm(2,204lbs/inch)
Dimensions - Body	Φ 6.29" x 3.93" / Φ 160mm x 100mm
Raising above grade	0.275" / 7mm
Weight	6.61lbs / 3kg
Water protection	IP68

Fixture Dimensions

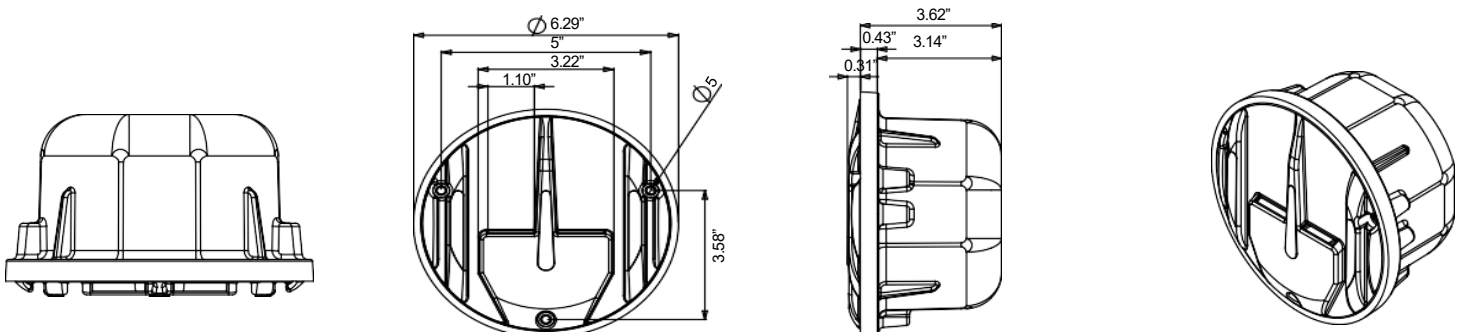

Flexible and Customizable:

- With a variety of LED colors the R1 can be configured to change colors as needed - an ideal feature for applications such as parking lot entrances, lane delineation and toll plaza lane signaling.
- Adjustable luminance levels
- Programmable Flashing, sequential flashing or steady lighting and timer configurations
- Optional PC, RF and GSM Remote control.

Incredibly durable and long lasting:

- Stainless steel body
- Military-grade high mechanical resistance design - resistant to tanks, trucks, snow plows and other heavy machinery
- High compression strength (1000kg / cm)
- Absolute water resistance (IP68)

SOLAR STREET LIGHT

USES AND APPLICATIONS GUIDE

Tunnels	
Parking lots	
Indoor spaces	
Walkways	
In-Ground signaling applications	
Crosswalks, bike and pedestrian lanes	
Ship and water craft decks	
Hotel entrances	
Gas stations	

ORDERING GUIDE

Ordering Guide: EXAMPLE: LINELIGHT R1-XY

Model	LED Color
Linelight R1	x – LEDS bank side 1 y – LEDS bank side 2 A – Amber W – White B – Blue R – Red G – Green N – None (for one-side units)

Legal Clarification: All technical information and/or products listings and/or technical support, and/or any kind of graphics, illustrations and/or instructions and/or the names, trade names, trademarks, trade symbols, service marks, logos, icons and trade dress of SolarPath Inc or in connection to SolarPath Inc or any of its selling products, contained herein is in the exclusive ownership of SolarPath Inc and may not be alternated and/or used in any manner including but not limited to copy of some or all of the said material by users and/or viewers or any third party for that matter of this document and the website to which it is linked without the express prior written permission of SolarPath Inc. Furthermore, redistribution or any kind of commercial use or alternation or any kind of use other than downloading presented information in some or all contents of downloadable documents, and/or downloadable contents, is strictly prohibited without express written prior permission. All information set out herein is subject to changes as may occur from time to time. SolarPath Inc is not responsible for, and cannot guarantee and shall not be held liable for any information or the accuracy of such in websites that it does not manage



Contact us



+1.201.490.4499

Toll free: 1.888.333.SOLAR (7652)



contact@solarpathusa.com



www.solarpathusa.com